



ACROW IMP

NR Collets for Drill

AA Grade	A Grade	Part No. Ød	ØD1	L
NR10AA - XXXX	NR10A - XXXX	3; 3.5; 4; 4.5.....10	15.6	30.6
NR16AA - XXXX	NR16A - XXXX	4; 4.5; 5; 5.5.....16	24.6	45.0

NR Collets for End-mills

AA Grade	A Grade	Part No. Ød	ØD1	L
NR10AA - EXXX	NR10A - EXXX	3; 4; 5; 6; 8; 10	15.5	30.6
NR16AA - EXXX	NR16A - EXXX	4; 5; 6.....16	24.2	45.0

Part No.	Ød	L1
NR10AA	3, 3.5	18
	4, 4.5	20
	5, 5.5	22
	6, 6.5, 7, 7.5	23
	8, 8.5, 9, 9.5	24
	10	31

Part No.	Ød	L1
NR16AA	3, 3.5	18
	4, 4.5	20
	5, 5.5	22
	6, 6.5, 7, 7.5	25
	8, 8.5, 9, 9.5	30
	10, 10.5, 11, 11.5	34
	12, 12.5, 13, 13.5	
	14, 14.5, 15, 15.5	35
16	45	

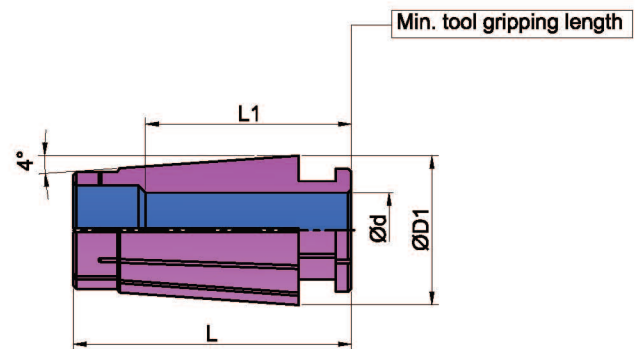

Tool shank (tolerance: h6)

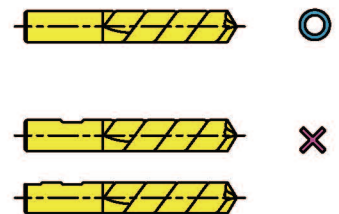

Part No.	Collets
NR10P	NR10
NR16P	NR16

Attaching & Detaching collet

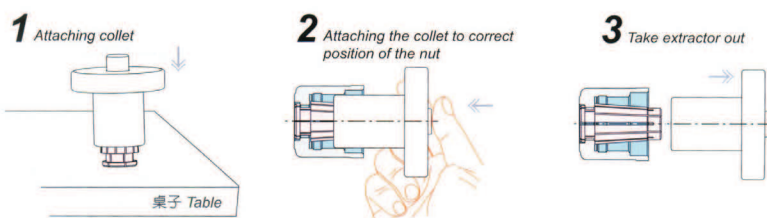

*Detaching: reverse step.