

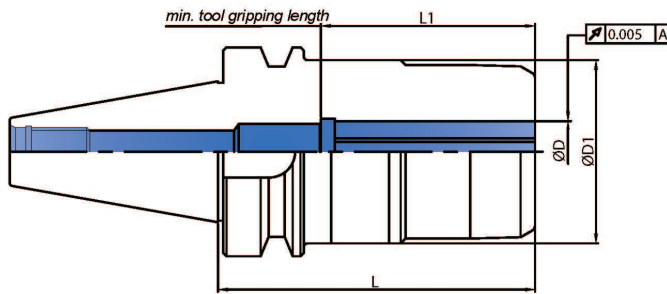

C-H HIGH SPEED PRECISION POWER MILLING CHUCKS

ACROW IMP



*Special design of dust-proof extends 50% or more lifetime of tool holders.
 *Caution: Excessive tightening torque will damage the chuck, nut or / and collet permanently!

Part No.	L	ØD H5	ØD1	L1	Collets	Wrench
BT30-C20H-085	85	20	50	57.5	ARH20	W-D48
BT40-C20H-090	90	20	50	57.5	ARH20	W-D48
C25H-090		25	57	60	ARH25	W-D55
C32H-090		32	69	64.5	ARH32	W-D68
-105	105	32	69	64.5	ARH32	W-D68
-120	120					
BT50-C20H-105	105	20	50	57.5	ARH20	W-D48
-165	165	25	57	60	ARH25	W-D55
-C25H-105	105					
-165	165					
-C32H-105	105	32	69	64.5	ARH32	W-D68
-165	165					

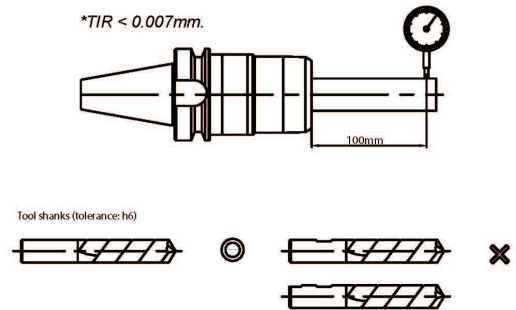

C Type Precision Power Milling Chuck

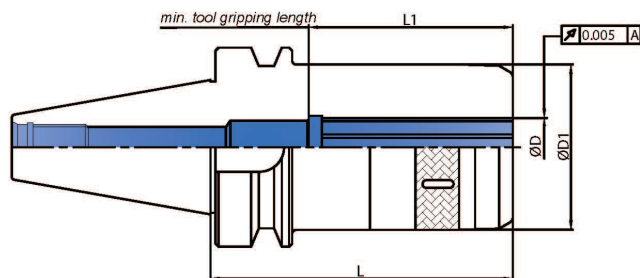

Part No.	L	ØD H5	ØD1	L1	Collets	Wrench
BT30-C20-085	85	20	50	57.5	ARH20	W-FK08
BT40-C20-090	90	20	50	57.5	ARH20	W-FK08
C25-090		25	57	60	ARH25	W-FK09
C32-090		32	69	64.5	ARH32	W-FK10
-105	105	32	69	64.5	ARH32	W-FK10
-120	120					
BT50-C20-105	105	20	50	57.5	ARH20	W-FK08
-165	165	25	57	60	ARH25	W-FK09
-C25-105	105					
-165	165					
-C32-105	105	32	69	64.5	ARH32	W-FK10
-165	165					

