

Fig.1

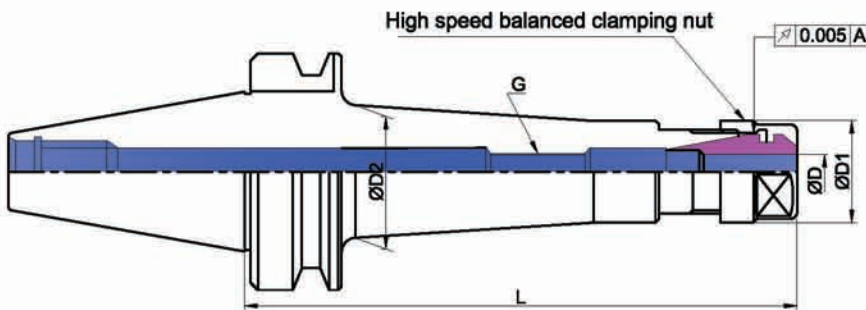

Fig.2



- ❖ Caution: Excessive tightening torque will damage the chuck, nut or / and collet permanently!
- ❖ Balanced to G2.5/20,000 rpm

Part No.	ØD Range	Fig.	L	ØD1	G	Nut	Collets	Wrench
BT30-ER11-075	Ø0.5 ~ Ø7.0	1	75	19	M08*P1.0	ER11	ER11	W-ER11
-100			100					
-ER16-060	Ø0.5 ~ Ø10.0		60	28	M11*P1.0	ER16	ER16	W-ER16
-100			100					
-ER20-060	Ø1.0 ~ Ø13.0		60	34	M14*P1.0	ER20	ER20	W-ER20
-100			100					
-140			140					
-ER25-060	Ø1.0 ~ Ø16.0		60	42	M18*P1.5	ER25	ER25	W-ER25
-100			100					
-ER32-070	Ø2.0 ~ Ø20.0		70	50	M24*P1.5	ER32	ER32	W-ER32
-100		100						
BT30-ER16M-070	Ø0.5 ~ Ø10.0	1	70	50	M11*P1.0	ER16M	ER16	W-ER16M
-100			100					



Part No.	ØD Range	Fig.	L	ØD2	ØD1	G	Nut	Collets	Wrench
BT40-ER11-075	Ø0.5 ~ Ø7.0	1	75	-	19	M08*P1.0	ER11	ER11	W-ER11
-100			100						
-ER16-070			Ø0.5 ~ Ø10.0						
-100	100								
-120	120								
-150	150								
-200	200	38							
-ER20-070	Ø1.0 ~ Ø13.0	1	70	-	34	M14*P1.0	ER20	ER20	W-ER20
-100			100						
-120			120						
-150			150						
-200			200						
-ER25-070	Ø1.0 ~ Ø16.0	1	70	-	42	M18*P1.5	ER25	ER25	W-ER25
-100			100						
-120			120						
-150			150						
-ER32-070			Ø2.0 ~ Ø20.0						
-100	100								
-120	120								
-150	150								
-ER40-080	Ø3.0 ~ Ø26.0	1		80	-	63	M10*P1.5	ER40	ER40
-120			120	M28*P1.5					
BT40-ER11M-100	Ø0.5 ~ Ø7.0	1	100	-	12	M08*P1.0	ER11M	ER11	W-ER11M

BT50-ER16-100	Ø0.5 ~ Ø10.0	1	100	-	28	M11*P1.0	ER16	ER16	W-ER16	
-120			120							
-150			150							
-250			250							38
-ER20-100	Ø1.0 ~ Ø13.0	1	100	-	34	M14*P1.0	ER20	ER20	W-ER20	
-120			120							
-150			150							
-200			200							44
-250			250							54
-ER25-070			Ø1.0 ~ Ø16.0							1
-150	150									
-200	200									
-ER32-070	Ø2.0 ~ Ø20.0	1		70	-	50	M24*P1.5	ER32	ER32	
-100			100							
-150			150							
-200			200	60						
-250			250							
-ER40-080			Ø3.0 ~ Ø26.0	1						80
-150	150									
-250	250									
-ER50-090	Ø12.0 ~ Ø34.0	1			80	-	78	M10*P1.5	ER50	ER50
-150			150							

ER COLLET CHUCKS, FINE BALANCED (DIN6499)

ACROW IMP

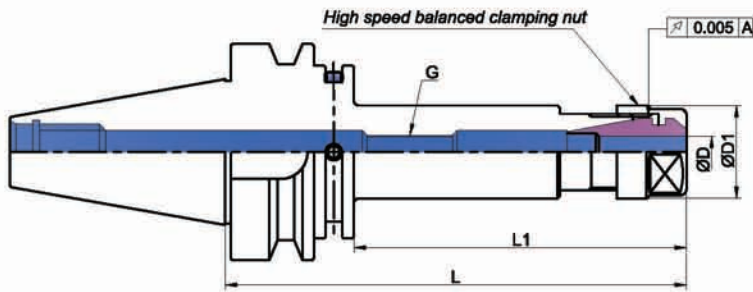

- ❖ Caution: Excessive tightening torque will damage the chuck, nut or / and collet permanently!
- ❖ Balanced to G2.5/20,000 rpm

Part No.	ØD Range	L	L1	ØD1	G	Nut	Collets	Wrench
BT30-ER11-075G	Ø0.5 ~ Ø7.0	75	44.5	19	M08*P1.0	ER11	ER11	W-ER11
-ER16-075G	Ø0.5 ~ Ø10.0	80	49.5	28	M11*P1.0	ER16	ER16	W-ER16
-100G		110	79.5					
-ER20-070G	Ø1.0 ~ Ø13.0	80	49.5	34	M14*P1.0	ER20	ER20	W-ER20
-100G		110	79.5					
-ER25-070G	Ø1.0 ~ Ø16.0	80	49.5	42	M18*P1.5	ER25	ER25	W-ER25
-100G		100	69.5					
-ER32-070G	Ø2.0 ~ Ø20.0	80	49.5	50	M10*P1.5	ER32	ER32	W-ER32
-100G		100	69.5		M24*P1.5			

BT40-ER11-100G	Ø0.5 ~ Ø7.0	100	61.5	19	M08*P1.0	ER11	ER11	W-ER11
-ER16-100G	Ø0.5 ~ Ø10.0	110	71.5	28	M11*P1.0	ER16	ER16	W-ER16
-120G		130	91.5					
-ER20-100G	Ø1.0 ~ Ø13.0	110	71.5	34	M14*P1.0	ER20	ER20	W-ER20
-130G		140	101.5					
-ER25-100G	Ø4.0 ~ Ø16.0	100	61.5	42	M18*P1.50	ER25	ER25	W-ER25
-ER32-070G	Ø2.0 ~ Ø20.0	75	34	50	M24*P1.5	ER32	ER32	W-ER32
-100G		100	73					

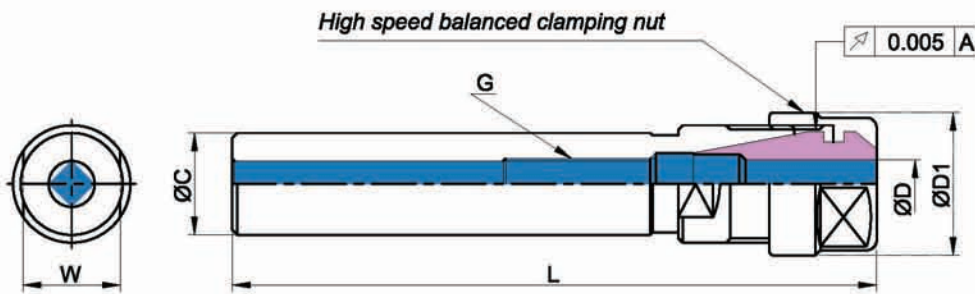

❖ Caution : Excessive tightening torque will damage the chuck, nut or / and collet permanently!

Part No.	ØD Range	L	ØC	W	ØD1	G	Nut	Collets	Wrench
ST16-ER11-150	Ø0.5 ~ Ø7.0	150	16	16	19	M08*P1.0	ER11	ER11	W-ER11
ST20-ER16-100	Ø0.5 ~ Ø10.0	100	20	19	28	M11*P1.0	ER16	ER16	W-ER16
-150		150							
-200		200							
-ER20-100	Ø1.0 ~ Ø13.0	100	22	34	M14*P1.0	ER20	ER20	W-ER20	
-150		150							
-200		200							
ST32-ER20-100	Ø1.0 ~ Ø13.0	100	32	29	34	M14*P1.0	ER20	ER20	W-ER20
-150		150							
-200		200							
-ER25-100	Ø1.0 ~ Ø16.0	100	42	-	M18*P1.5	ER25	ER25	W-ER25	
-150		150							
ST40-ER25-100	Ø1.0 ~ Ø16.0	100	40	38	42	-	ER25	ER25	W-ER25
-ER32-100	Ø2.0 ~ Ø20.0								

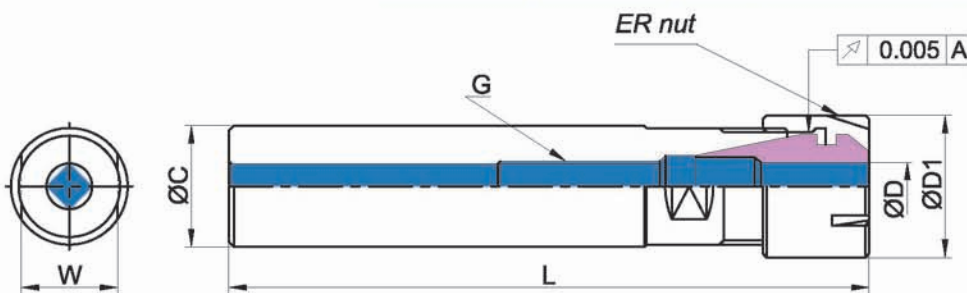

Part No.	ØD Range	L	ØC	W	ØD1	G	Nut	Collets	Wrench
ST12-ER08M-150	Ø0.5 ~ Ø5.0	150	12	10	12	M05*P0.8	ER08M	ER08	W-ER08M
ST16-ER11M-150	Ø0.5 ~ Ø7.0	150	16	14	16	M08*P1.0	ER11M	ER11	W-ER11M
ST20-ER16M-100	Ø0.5 ~ Ø10.0	100	20	19	22	M11*P1.0	ER16M	ER16	W-ER16M
-150		150							
-200		200							
-ER20M-100	Ø1.0 ~ Ø13.0	100	22	28	M14*P1.0	ER20M	ER20	W-ER20M	
-150		150							
-200		200							

❖ ER collets and wrenches, to be ordered separately.