

Fig.1

Ø25~40

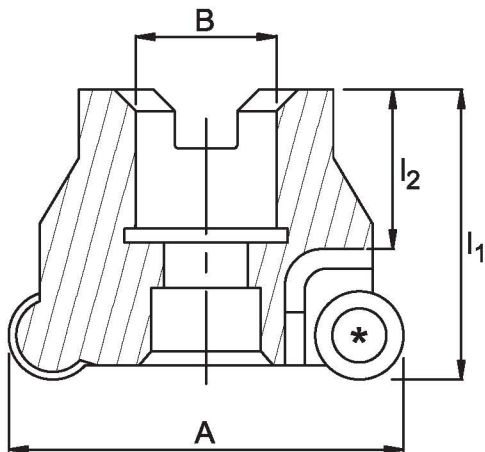

Fig.2

Ø50~80

Dimensions in mm				No. of inserts	Insert designation	Fig
A	B	l1	l2			
25	25	110	50	2	RD.T 1003 RD.T 1204	1
32	25	130	70	3		
40	32	130	70	4		
50	22	50	20	4	RD.T 1003 RD.T 1204	2
63	22	50	20	4		
80	27	55	20	4		

Spare Parts

Insert	Insert screw	Torx driver
RD.T 1003	M3.5 x 0.60	T 15
RD.T 1204	M4.5 x 0.75	T 20

Note: We can suit ISO insert any make like SANDVIK, SECO, WIDIA, KORLOY, MITSUBISHI, ISCAR, TAEGUTEC, PLANSEE TIZIT, KYOCERA etc.,



MTS SQ. SHOULDER AND SLOT MILLING CUTTER

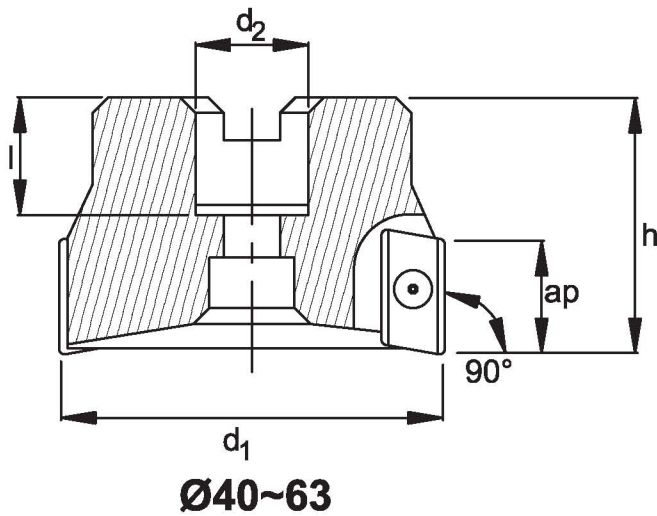

Dimensions in mm					No. of inserts	Insert designation
Ød1	d2	h	l	max ap		
40	22	40	20	8	4	XDHT 09 03
50	22	40	20	8	4	
63	22	40	20	8	6	
40	22	40	20	14	4	XPHT 16 04
50	22	40	20	14	4	
63	22	40	20	14	4	

Spare Parts

Insert	Insert screw	Torx key
XDHT 0903	M2.5 x 0.45	T 8
XPHT 1604	M3.5 x 0.60	T 15

Note: We can suit ISO insert any make like SANDVIK, SECO, WIDIA, KORLOY, MITSUBISHI, ISCAR, TAEGUTEC, PLANSEE TIZIT, KYOCERA etc.,

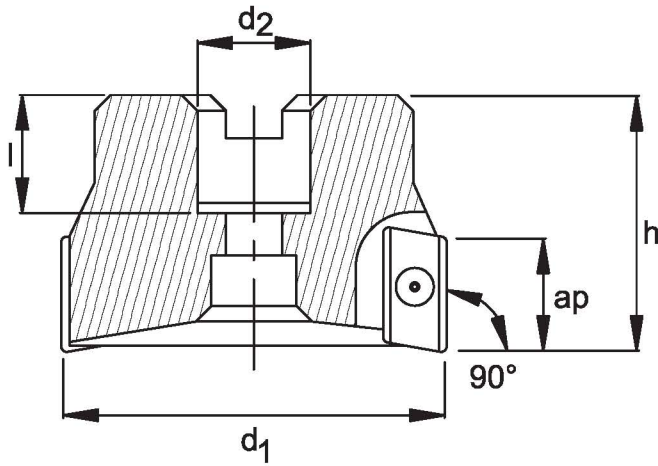

Ø50~80

Dimensions in mm					No. of inserts	Insert designation
Ød1	d2	h	l	max ap		
50	22	40	20	10	4	APMT 1135
63	22	40	20	10	4	
80	27	50	22	10	4	
50	22	40	20	12	4	APMT 1604
63	22	40	20	12	4	
80	27	50	22	12	4	

Spare parts

Insert	Insert screw	Torx key
APMT 1135	M2.5 X 0.45	T 8
APMT 1604	M3.5 X 0.60	T 15

Note: We can suit ISO insert any make like SANDVIK, SECO, WIDIA, KORLOY, MITSUBISHI, ISCAR, TAEGUTEC, PLANSEE TIZIT, KYOCERA etc.,