

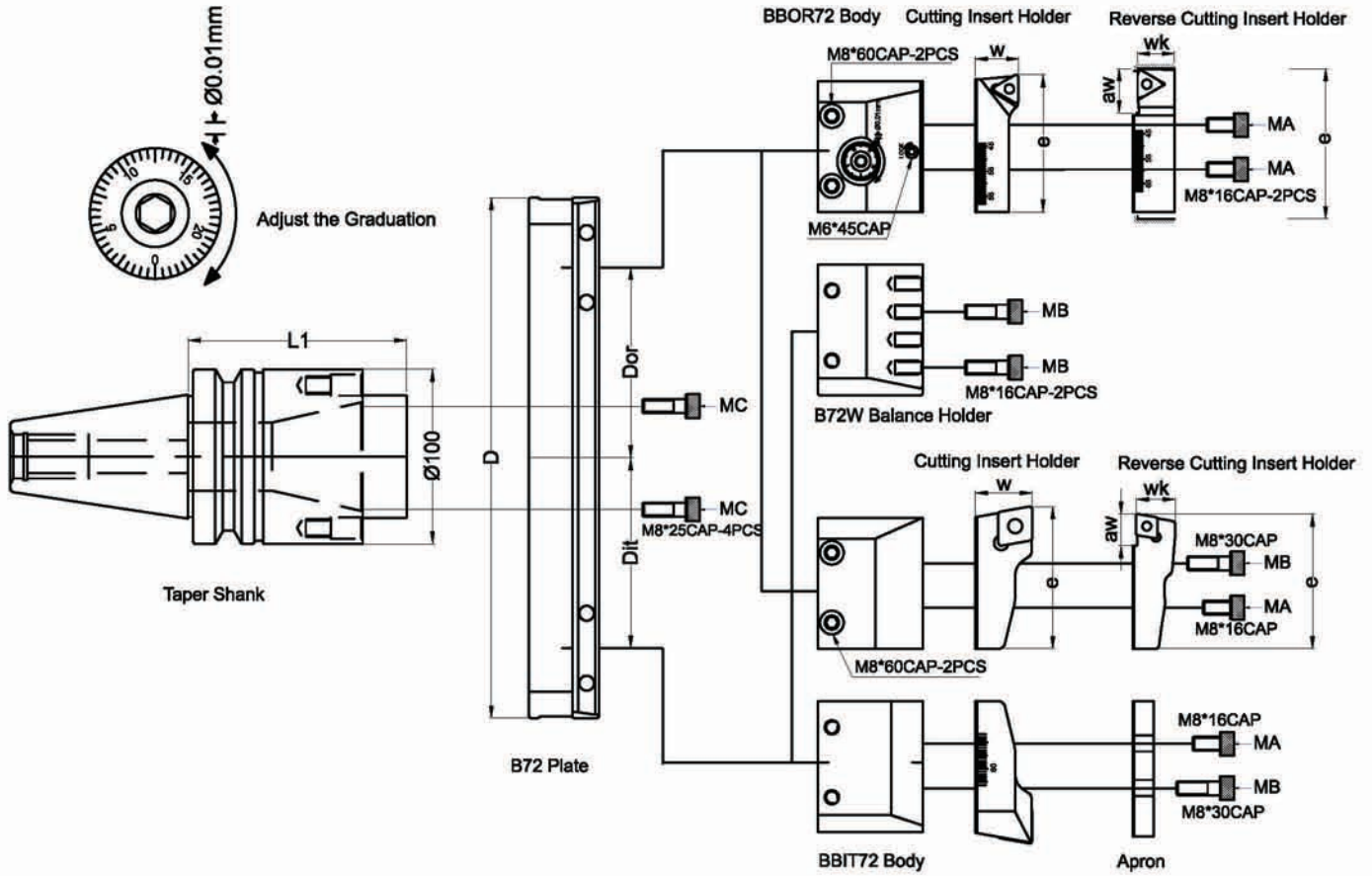

B72 LARGE DIAMETER BORING SYSTEM

STANNY IMP



Model	L1	MC Bolt	N.W.
BT50-B72-85	85	CAP M8*25-4PCS	4.20
BT50-B72-125	125		6.10
BT50-B72-175	175		8.75



Model	D	BBOR Dor	BBIT Dit	N.W.
B72-148	148	40	35	2.15
B72-198	198	65	60	3.00
B72-248	248	90	85	3.80
B72-298	298	115	110	4.60
B72-348	348	140	135	5.40
B72-398	398	165	160	6.20



B72 LARGE DIAMETER BORING SYSTEM

STANNY IMP

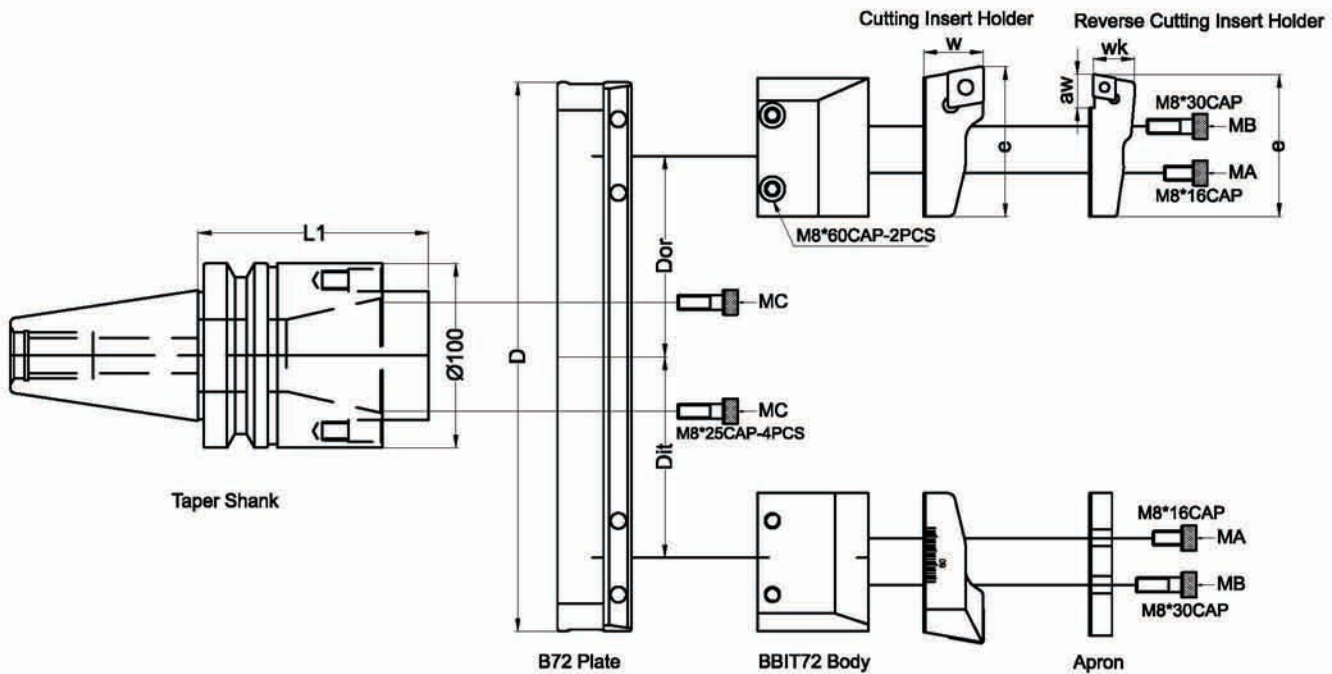

Model	Mobile	MA Bolt	MB Bolt	Wrench	N.W.
BBIT72	20	CAP M8*16	CAP M8*30	Ø4 Ø6	1.44



Model	W	e	Insert	Bolt	Wrench	N.W.
SACC90130	22.6	79.5	CCMT1204..	M5-TS5	T25	0.17
SBCC90130						0.18
SACC130170		99.5				0.23
SBCC130170						0.24



Model	aw	wk	e	Insert	Bolt	Wrench	N.W.
RKCC90130	22	22	79.5	CCMT1204..	M5-TS5	T25	0.18
RKCC130170	44		99.5				0.25



B72 LARGE DIAMETER BORING SYSTEM

STANNY IMP

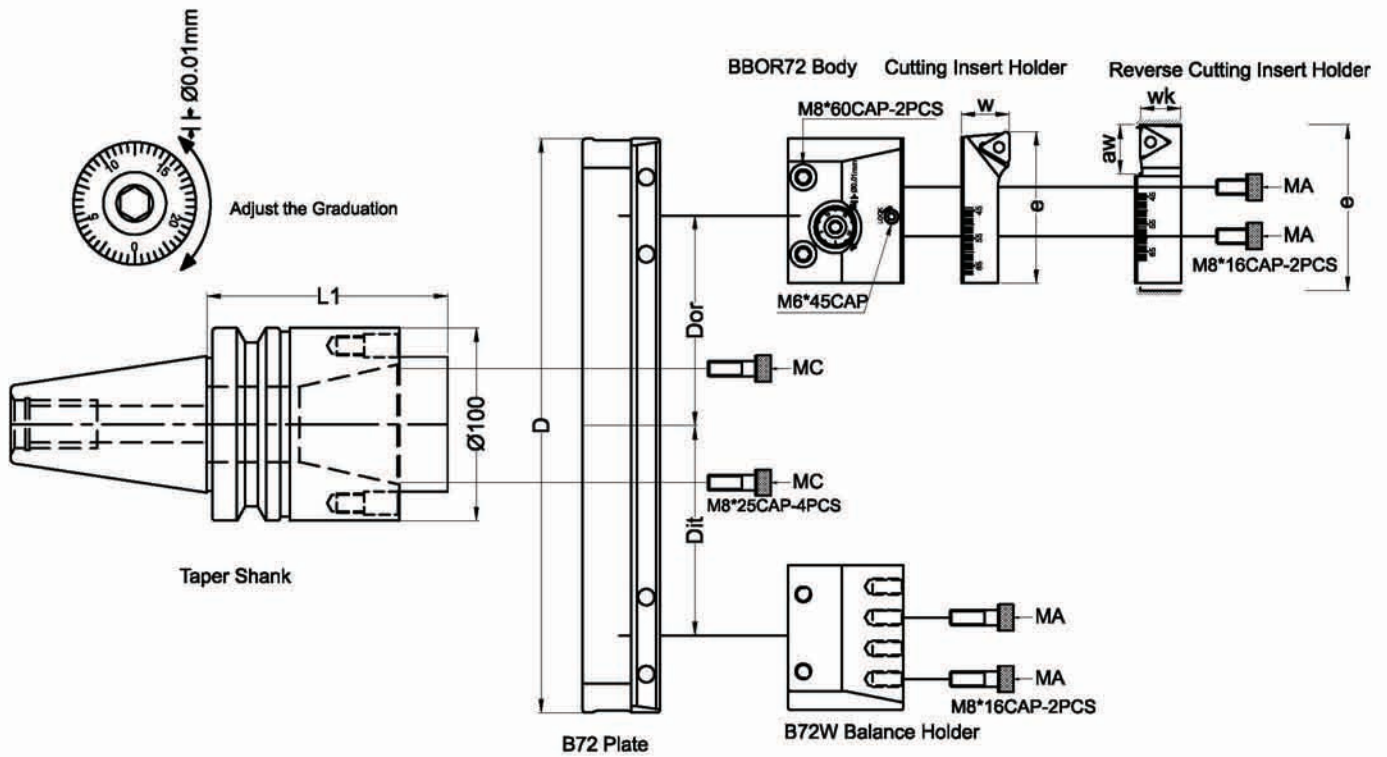

Model	Mobile	MA Bolt	Wrench	N.W.
BBOR72	10	CAP M8*16	⊘ 5 ⊘ 6	1.65
B72W			⊘ 6	1.59

Model	W	e	Insert	Bolt	Wrench	N.W.
SRTP70110	20	66	TPGH1103..L	SB-3TR-M3	T8	0.10
SRTP110150	20	106				0.21

Model	aw	wk	e	Insert	Bolt	Wrench	N.W.
FKTP70110	16	15	66	TPGH1103..L	SB-3TR-M3	T8	0.10
FKTP110150	25		106				0.21

B • BIT72 LARGE DIAMETER BORING SYSTEM

STANNY IMP

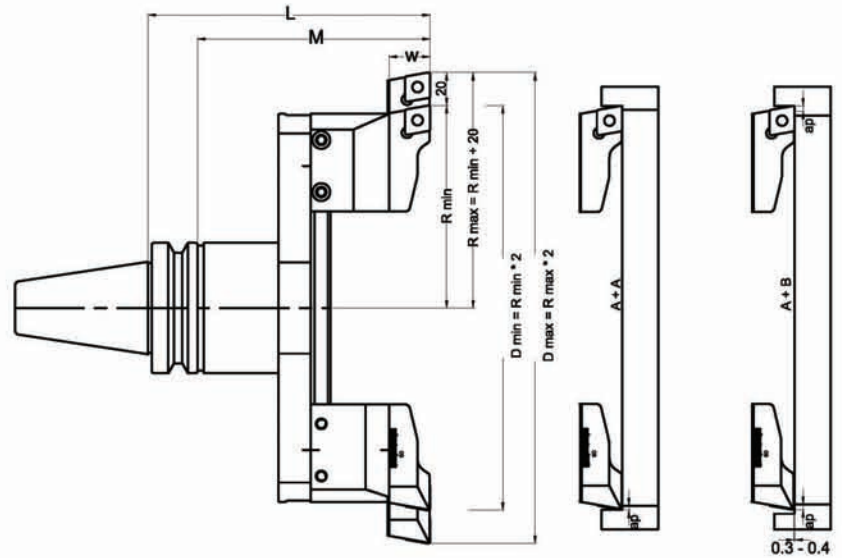

MAS403 BT-B-BIT72 Large Diameter Adjustable Twin Cutter Roughing and Semi-Finishing Boring System

Model	Boring Range ØDmin ~ ØDmax	M	L	Micro-Finishing Cutter for Reverse Fine Boring System				N.W.					
				Taper Shank	Plate	Boring Head	Cutting Insert Holder						
BT50-BBIT72-112 AB	160 ~ 200	112	165	BT50-B72-85	B72-148	BBIT72	SACC90130 SBCC90130	9.58					
BT50-BBIT72-112 AB	210 ~ 250				B72-198			10.43					
BT50-BBIT72-112 AB	260 ~ 300				B72-248			11.23					
BT50-BBIT72-112 AB	310 ~ 350				B72-298			12.03					
BT50-BBIT72-112 AB	360 ~ 400				B72-348			12.83					
BT50-BBIT72-112 AB	410 ~ 450				B72-398			13.63					
BT50-BBIT72-112 AB	200 ~ 240				B72-148			9.70					
BT50-BBIT72-112 AB	250 ~ 290				B72-198			10.55					
BT50-BBIT72-112 AB	300 ~ 340				B72-248			11.35					
BT50-BBIT72-112 AB	350 ~ 390				B72-298			12.15					
BT50-BBIT72-112 AB	400 ~ 440				B72-348			12.95					
BT50-BBIT72-112 AB	450 ~ 490				B72-398			13.75					
BT50-BBIT72-152 AB	160 ~ 200				152			205	BT50-B72-125	B72-148	BBIT72	SACC90130 SBCC90130	11.48
BT50-BBIT72-152 AB	210 ~ 250									B72-198			12.33
BT50-BBIT72-152 AB	260 ~ 300	B72-248	13.13										
BT50-BBIT72-152 AB	310 ~ 350	B72-298	13.93										
BT50-BBIT72-152 AB	360 ~ 400	B72-348	14.73										
BT50-BBIT72-152 AB	410 ~ 450	B72-398	15.53										
BT50-BBIT72-152 AB	200 ~ 240	B72-148	11.60										
BT50-BBIT72-152 AB	250 ~ 290	B72-198	12.45										
BT50-BBIT72-152 AB	300 ~ 340	B72-248	13.25										
BT50-BBIT72-152 AB	350 ~ 390	B72-298	14.05										
BT50-BBIT72-152 AB	400 ~ 440	B72-348	14.85										
BT50-BBIT72-152 AB	450 ~ 490	B72-398	15.65										
BT50-BBIT72-202 AB	160 ~ 200	202	255	BT50-B72-175		B72-148	BBIT72			SACC90130 SBCC90130			14.13
BT50-BBIT72-202 AB	210 ~ 250					B72-198							14.98
BT50-BBIT72-202 AB	260 ~ 300				B72-248	15.78							
BT50-BBIT72-202 AB	310 ~ 350				B72-298	16.58							
BT50-BBIT72-202 AB	360 ~ 400				B72-348	17.38							
BT50-BBIT72-202 AB	410 ~ 450				B72-398	18.18							
BT50-BBIT72-202 AB	200 ~ 240				B72-148	14.25							
BT50-BBIT72-202 AB	250 ~ 290				B72-198	15.10							
BT50-BBIT72-202 AB	300 ~ 340				B72-248	15.90							
BT50-BBIT72-202 AB	350 ~ 390				B72-298	16.70							
BT50-BBIT72-202 AB	400 ~ 440				B72-348	17.50							
BT50-BBIT72-202 AB	450 ~ 490				B72-398	18.30							



B • BOR72 LARGE DIAMETER BORING SYSTEM



STANNY IMP

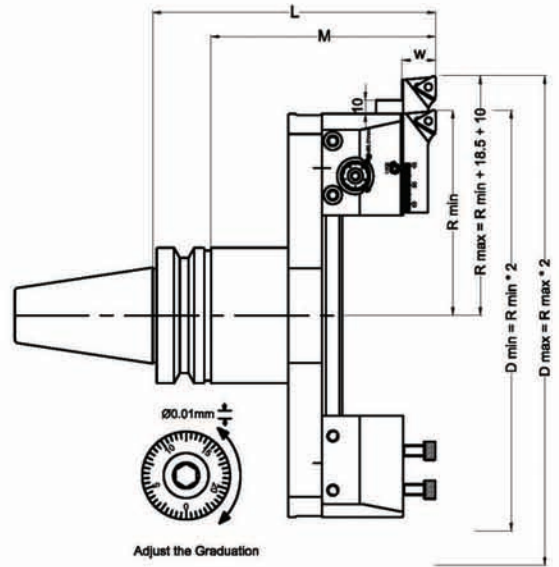

MAS403 BT-Bor72 Large Diameter Finishing Cutter Fine Boring System

Model	Boring Range ØDmin ~ Ødmax	M	L	Micro-Finishing Cutter for Reverse Fine Boring System				N.W.
				Taper Shank	Plate	Boring Head	Cutting Insert Holder	
BT50-BBOR72-112 M	150 ~ 207	112	165	BT50-B72-85	B72-148	SRTP70110	9.69	
BT50-BBOR72-112 M	200 ~ 257				B72-198		10.54	
BT50-BBOR72-112 M	250 ~ 307				B72-248		11.34	
BT50-BBOR72-112 M	300 ~ 357				B72-298		12.14	
BT50-BBOR72-112 M	350 ~ 407				B72-348		12.94	
BT50-BBOR72-112 M	400 ~ 457				B72-398		13.74	
BT50-BBOR72-112 M	190 ~ 247				B72-148		SRTP110150	9.80
BT50-BBOR72-112 M	240 ~ 297				B72-198			10.65
BT50-BBOR72-112 M	290 ~ 347				B72-248			11.45
BT50-BBOR72-112 M	340 ~ 397				B72-298			12.25
BT50-BBOR72-112 M	390 ~ 447				B72-348			13.05
BT50-BBOR72-112 M	440 ~ 497				B72-398			13.85
BT50-BBOR72-152 M	150 ~ 207	152	205	BT50-B72-125	B72-148	SRTP70110	11.59	
BT50-BBOR72-152 M	200 ~ 257				B72-198		12.44	
BT50-BBOR72-152 M	250 ~ 307				B72-248		13.24	
BT50-BBOR72-152 M	300 ~ 357				B72-298		14.01	
BT50-BBOR72-152 M	350 ~ 407				B72-348		14.84	
BT50-BBOR72-152 M	400 ~ 457				B72-398		15.64	
BT50-BBOR72-152 M	190 ~ 247				B72-148	SRTP110150	11.70	
BT50-BBOR72-152 M	240 ~ 297				B72-198		12.55	
BT50-BBOR72-152 M	290 ~ 347				B72-248		13.35	
BT50-BBOR72-152 M	340 ~ 397				B72-298		14.15	
BT50-BBOR72-152 M	390 ~ 447				B72-348		14.95	
BT50-BBOR72-152 M	440 ~ 497				B72-398		15.75	
BT50-BBOR72-202 M	150 ~ 207	202	255	BT50-B72-175	B72-148	SRTP70110	14.24	
BT50-BBOR72-202 M	200 ~ 257				B72-198		15.09	
BT50-BBOR72-202 M	250 ~ 307				B72-248		15.89	
BT50-BBOR72-202 M	300 ~ 357				B72-298		16.69	
BT50-BBOR72-202 M	350 ~ 407				B72-348		17.49	
BT50-BBOR72-202 M	400 ~ 457				B72-398		18.29	
BT50-BBOR72-202 M	190 ~ 247				B72-148	SRTP110150	14.35	
BT50-BBOR72-202 M	240 ~ 297				B72-198		15.20	
BT50-BBOR72-202 M	290 ~ 347				B72-248		16.00	
BT50-BBOR72-202 M	340 ~ 397				B72-298		16.80	
BT50-BBOR72-202 M	390 ~ 447				B72-348		17.60	
BT50-BBOR72-202 M	440 ~ 497				B72-398		18.40	